



THE HEART OF EVERY GREAT MACHINE

GENERATING SET MODEL (NBS P 550)

Output Ratings	Prime	Standby
380-415 V, 3 ph, 50 Hz, 1500 rpm	500 KVA 400 KW	550 KVA 440 KW
380-415 V, 3 ph, 60 Hz, 1800 rpm	500 KVA 400 KW	563 KVA 450 KW

ENGINE / TECHNICAL DATA

Ratings at 0.8 Power Factor

Engine Make	Perkins	
Engine Model	2506A-E15TAG2/2506C-E15TAG2	
Governing Type	Electronic	
Number of Cylinders	6	
Cylinder Arrangement	Vertical in line	
Bore and Stroke mm	137 x 171	
Displacement / Cubic Capacity litres	15.2	
Induction System	Turbocharged and air to air charge cooled	
Cycle	4 stroke	
Combustion System	Direct Injection	
Compression Ratio	16:1	
Rotation	Anti-clockwise, viewed on flywheel	
Cooling System	Water - cooled	
Frequency and Engine Speed	50Hz & 1500rpm	60Hz & 1800rpm
Gross Engine Power kW (hp)	451 (605)	495 (664)
Fuel Consumption @ 50% load L/hr	50	52
@ 75% load L/hr	72	78
@ 100% load L/hr	95	102
Total Lubrication System Capacity litres	62	62
Total Coolant Capacity litres	58	58
Exhaust Temperature: °C	500	550

ALTERNATOR DATA

Make	UPS / Leroy Somer
Model	UPS354D/LSA (TAL) 047C
No. of bearings	1
Insulation class	H
Wires	6/12
Ingress Protection	IP23
Excitation System	SHUNT
Winding Pitch	2/3

Overspeed	2250 mn ⁻¹
Voltage Regulation (steady)	± 1%

CONTROL PANEL

Make	Deep Sea
Model	4000 SERIES

The **DSE 4000 Series** is an Auto Start Control for single genset applications. It includes a LCD display which clearly shows the status of engine all the times. This module can either be programmed using the front panel or by using the DSE configuration suite PC software.

Metering and Alarm indications:

- Generator frequency
- Underspeed, Overspeed
- Generator volts (L-L, L-N)
- Generator current
- Engine oil pressure
- Engine coolant temperature
- Hours run counter
- Battery volts
- Fail to start/stop
- Emergency stop
- Failed to reach loading voltage/frequency
- Charge fail
- Low DC voltage
- CAN diagnostics and CAN fail/error



1. ENGINE

Perkins four stroke heavy duty high performance industrial type diesel engine.

2. ENGINE FILTRATION SYSTEM

- Cartridge type dry air filter.
- Two Cartridge type fuel filters.
- Full flow lube oil filter.

All filters have replaceable elements.

3. COOLING RADIATOR

Radiator and cooling fan, complete with safety guards, designed to cool the engine at high ambient temperatures (consult your dealer for de-rating factors)

4. EXHAUST SYSTEM

Exhaust gas flow ? ? ? 98 m³/min
Maximum allowable back pressure 6.80 (kPa)

5. CIRCUIT BREAKER TYPE

3 pole MCCB. (4 pole is optional)

6. FUEL SYSTEM

The baseframe design is incorporated with an integral fuel tank with a capacity of approx. 8 hours running at Full Load. The tank is supplied complete with fill cap breather, fuel feed and return lines to the Engine and drain plug.

7. ALTERNATOR

7.1 INSULATION SYSTEM

- The insulation system is Class H.
- All windings are impregnated in either a triple dip thermosetting liquid, oil and acid resisting polyester varnish or vacuum pressure impregnated with a special polyester resin.
- Heavy coat of antitracking varnish additional protection against moisture or condensation.

7.2 AUTOMATIC VOLTAGE REGULATOR (AVR)

The fully sealed Automatic Voltage Regulator maintains the Voltage Regulation at $\pm 1\%$. Nominal adjustment by means of a trim pot incorporated on the AVR.

8. MOUNTING ARRANGEMENT

8.1 COUPLING

The Engine and Alternator are directly coupled by means of an SAE flange. The Engine flywheel is flexibly coupled to the Alternator rotor.

8.2 ANTI-VIBRATION MOUNTING PADS

Anti-Vibration pads are affixed between the Engine / Alternator feet and the Baseframe thus ensuring complete vibration isolation of the rotating assembly.

8.3 SAFETY GUARDS

The Fan & Fan Drive along with the Battery Charging Alternator are Safety Guard protected for personnel protection.

9. FACTORY TEST

- The Generating set is load tested before dispatch
- All protective devices control functions and site load conditions are simulated. The generator and its systems are checked before dispatch.

10. EQUIPMENT FINISHING

All mild steel components are fully degreased and painted with powder coated paint to ensure maximum scuff resistance and durability.

11. DOCUMENTATION

Operation & Maintenance manual, Circuit wiring diagrams and Commissioning / Fault Finding instruction leaflets are accompanied with the Generator.

12. QUALITY STANDARDS

The equipment meets the following standards: BS4999, BS5000, BS5514 IEC 60034, VDE0530, NEMA MG 1.22 and ISO 8528.

13. WARRANTY

All of the Generating Sets are covered under a warranty policy for a period of 12 months or 1000 working hours. Warranty of the equipment is in line with manufacturers warranty terms & conditions.

(check warranty statement for more details, as it may vary for different countries)

In line with continuous product development, we reserve the right to change specifications without notice.

DIMENSIONS AND WEIGHT

Standard Generator

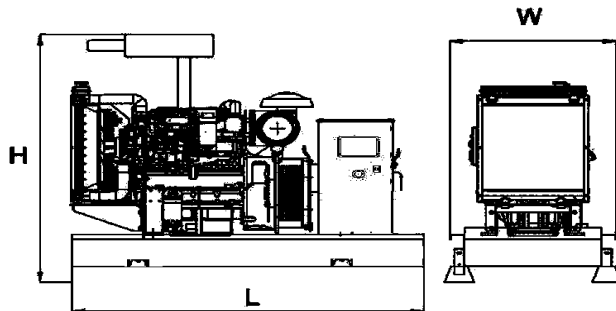

Length, L	3.9 m
Height, H	2.13 m
Width, W	1,1 m
Weight, Total	3528kg

Generator with Soundproof Canopy

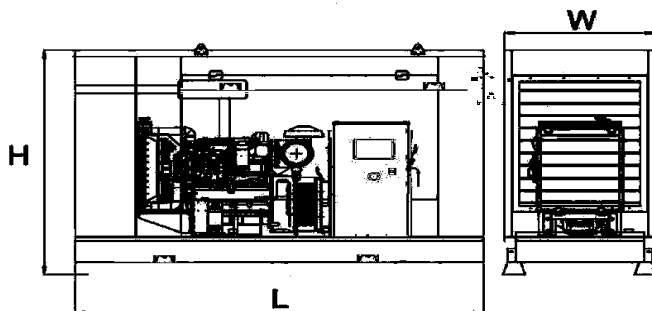

Length, L	4.44 m
Height, H	1.380 m
Width, W	2.4 m
Weight, Total	3920 kg